

## 17.ATF

### A: INSPECTION

1) Raise ATF temperature to 70 to 80°C (158 to 176°F) by driving for approx. 10 min.

#### NOTE:

The level of ATF varies with fluid temperature. Pay attention to the fluid temperature when checking oil level.

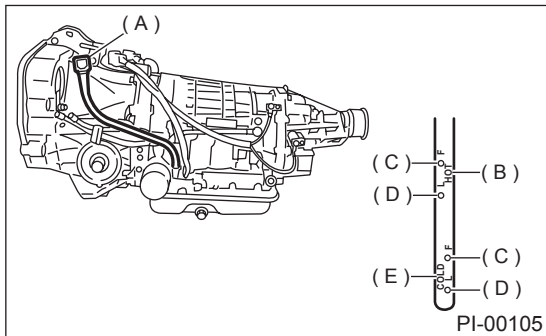

- (A) Level gauge
- (B) Check line, HOT condition
- (C) Upper level
- (D) Lower level
- (E) Check line, COLD condition

2) Make sure the vehicle is level. After selecting all positions (P, R, N, D, 3, 2, 1), set the select lever in "P" range. Measure fluid level with the engine idling.

#### NOTE:

After running, idle the engine for one or two minutes before measurement.

3) If the fluid level is below the center between upper and lower marks, add the recommended ATF until the fluid level is found within the specified range (above the center between upper and lower marks). When the transmission is hot, the level should be above the center of upper and lower marks, and when it is cold, the level should be found below the center of these two marks.

#### CAUTION:

- Use care not to exceed the upper limit level.
- ATF level varies with temperature. Remember that the addition of fluid to the upper limit mark when the transmission is cold will result in the overfilling of fluid.

4) Fluid temperature rising speed

- By idling the engine

Time for temperature rise to 70°C (158°F) with atmospheric temperature of 0°C (32°F): More than 25 minutes

<Reference>

Time for temperature rise to 30°C (86°F) with atmospheric temperature of 0°C (32°F): Approx. 8 minutes

- By running the vehicle

Time for temperature rise to 70°C (158°F) with atmospheric temperature of 0°C (32°F): More than 10 minutes

5) Method for checking fluid level upon delivery or at periodic inspection

Check fluid level after a warm-up run of approx. 10 minutes. During the warm-up period, the automatic transmission functions can also be checked.