

4EAT

Phase 2 Overview

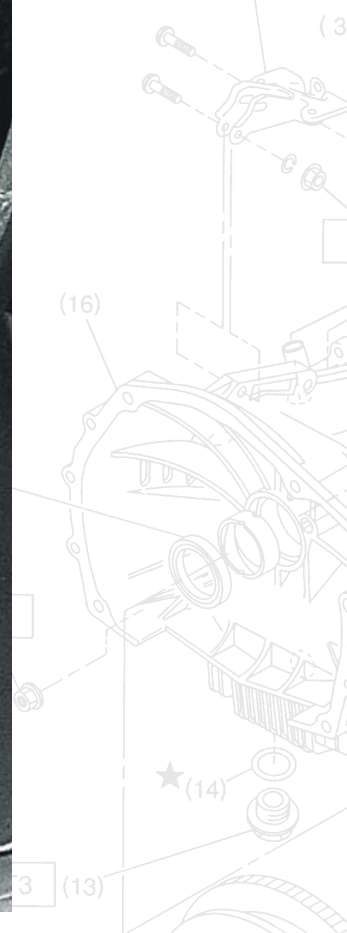

The 4EAT Phase 2 (introduced on 1999 model year Subaru vehicles) provides the same type of electronic control used by prior model year vehicles and shares many of the same diagnostic procedures. However, there have been internal and external changes that require this 4EAT to be viewed as an entirely new automatic transmission. Additionally, beginning with the 2001 model year, an enhancement to the all wheel drive transfer section was introduced. This enhancement, called Variable Torque Distribution (VTD), is included on all Subaru vehicles with Vehicle Dynamic Control (VDC). VTD is designed to smoothly transfer and divide the power from the engine to the wheels.

Several mechanical changes have been made for the 4EAT Phase 2 automatic transmission. These changes include: a new external oil filter, an additional speed sensor (for a total of three instead of just two), three new solenoids and the elimination of the 3-4 one-way clutch.

The external oil filter requires no scheduled maintenance, although it can be changed if necessary. The new filter is in addition to the metal valve body screen found on previous models. The screen is still present and can be flushed when the 4EAT is disassembled.

There are three speed sensors instead of the previous two: one for the front output shaft, one for the rear, and a new one that monitors the input speed of the torque converter turbine. All three

speed sensors are now located on the outside surface of the transmission case, reading the rotational speeds of internal components and improving transmission characteristics.

The speed sensor for the torque converter turbine allows the Transmission Control Module (TCM) to calculate the actual gear ratio in real time, by dividing the turbine speed by the output speed. To avoid shift shock and sluggish shifting, the rate of change of the actual gear ratio needs to be kept within a certain range. The TCM controls the duty ratios for the 2-4 brake, the high clutch, and the low clutch so that the rate of change occurs within the target range.

Externally, the number of bolts in the 4EAT Phase 2 torque converter housing area have increased to match the increase in the number of bolts in the bell housing of the engine.

Internally the Brake Band and Servo Mechanism have been deleted and in its place an additional clutch pack is used as a holding member for 2nd and 4th gears. Also, the remaining clutch assemblies and the valve body have been redesigned, requiring new disassembly and assembly procedures.

Because it is unlikely that you will be disassembling and servicing a Phase 2 transmission, this article will concentrate on transmission principles of operation and failure diagnosis. Detailed transmission disassembly and assembly information can be found in the service manual.

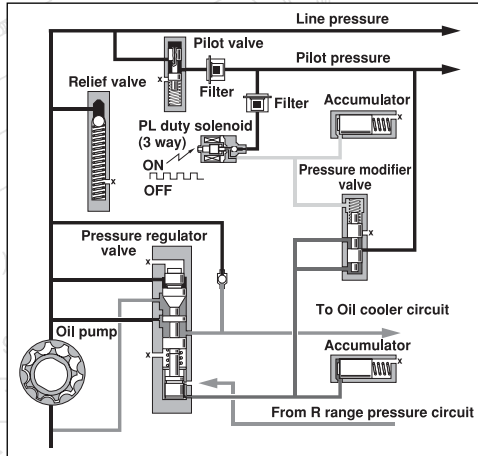

Line Pressure

Hydraulic Control Line Pressure

Line pressure provides the force necessary to engage driving and holding members as well as lubricate and cool the transmission. Adjusting the line pressure to various levels reduces the amount of load placed on the engine and minimizes wear on the transmission.

Line pressure is adjusted using data that indicates throttle opening, vehicle speed, and other input signals.

Control of the pressure during low load conditions results in a duty ratio, or on versus off time that is large. This duty ratio results in the PL Duty Solenoid staying on more than it is off. Pilot pressure is drained away from the Pressure Modifier Valve. Resulting circuit action lowers the pressure in the lower side of the Pressure Regulator Valve allowing line pressure in the upper side of the valve to push the valve down increasing the amount of pressure drained from the line pressure circuit.

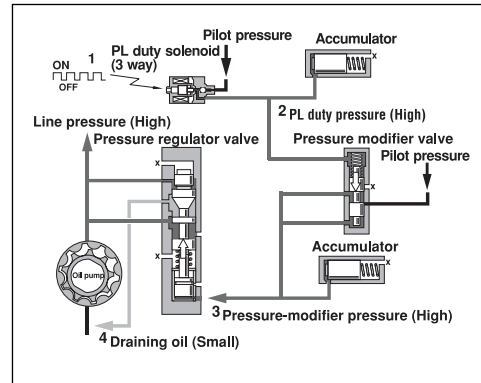

Line Pressure Detail

4EAT Phase 2 Overview

Control during high load conditions results in a low duty ratio increasing the pressure to the pressure modifier valve. This will result in an increase in pressure to the bottom of the pressure regulator valve, creating an upward movement of the pressure regulator valve and reducing the amount of line pressure drained. The amount of line pressure throughout the transmission will then increase.

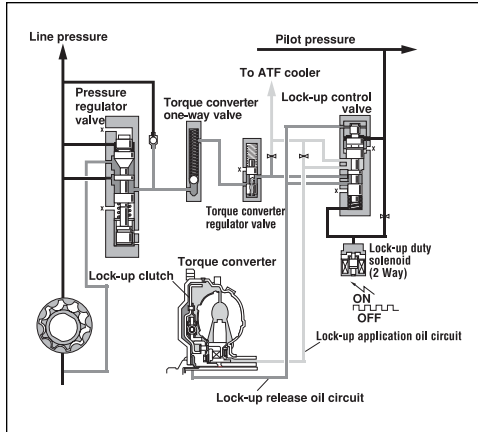

Lockup Engagement

Lock up control engages the Lock Up Clutch inside the Torque Converter when traveling in 4th gear under uniform conditions, transmitting engine power directly to the Input Shaft.

Lock up Engagement

1. The TCM increases the duty ratio and the oil drainage rate increases in proportion to the duty ratio.
2. The lock up control valve is pushed down, connecting the torque converter regulator valve port and the lock up application port.
3. Oil pressure from the Torque Converter Regulator Valve is conducted through the application port to the torque converter and the Torque Converter Clutch. The lock up release port ATF is drained through the lockup control valve at this time.
4. The lock up clutch is engaged by the oil pressure from the lock up application port. After the clutch is engaged, the TCM lock up duty solenoid ratio is fixed in the on position.

Lockup Release

1. The Duty Ratio of the Lockup solenoid is adjusted to 5%. Drainage of the duty solenoid oil is stopped and the lock up duty pressure rises.
2. The lockup control valve spool is pushed up, connecting the torque converter regulator valve port and the torque converter release port.
3. Oil pressure from the Torque Converter Regulator Valve is conducted through the release port to the Torque Converter Clutch and the Torque Converter Application Circuit.
4. The Clutch Plate moves away from the Torque Converter Case and the Lock up Clutch is released.

Gear Shift Control

The shift control operates the engagement and release of the Low Clutch, 2-4 Brake, and the High Clutch. TCM output signals control Shift Solenoid A and Shift Solenoid B based on input from vehicle speed and throttle opening.

The solenoids in turn supply or remove pilot pressure from Shift Valve A and Shift Valve B. The positioning of the shift valves route line pressure to the correct clutch and or brake assemblies.

1st Gear

When the selector lever is placed in the D range, the manual valve opens the port to the shift valves A and B, supplying Line pressure. Shift solenoids A and B are turned on by the TCM and pilot pressure is applied to the top of both shift valves. The shift valves move to the bottom of their bores, providing a route for line pressure to the Low Clutch.

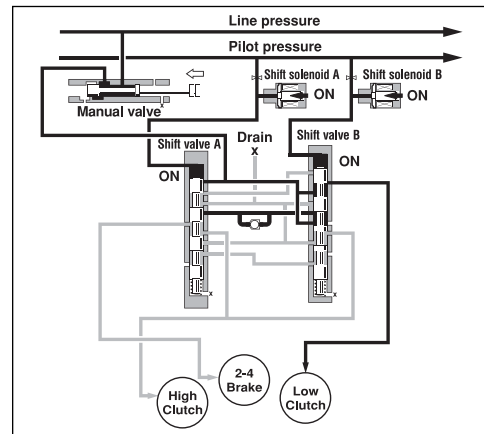

1st Gear

2nd Gear

TCM output turns shift solenoid A OFF and shift solenoid B ON. Shift valve A moves upward and opens the 2-4-Brake port. The Low Clutch and 2-4 brake are now applied.

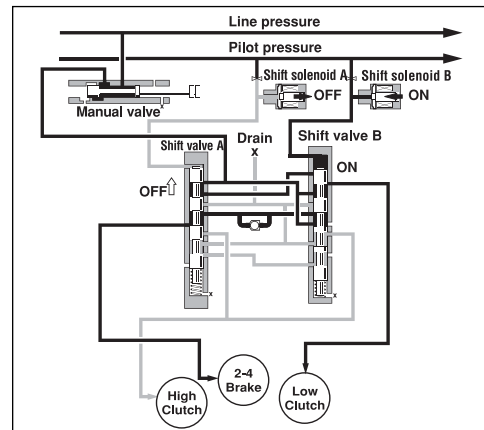

2nd Gear

3rd Gear

Both solenoids are turned off allowing the pilot pressure supplied to the shift valve to drain. The shift valves move upward allowing line pressure to the Low Clutch and the High Clutch.

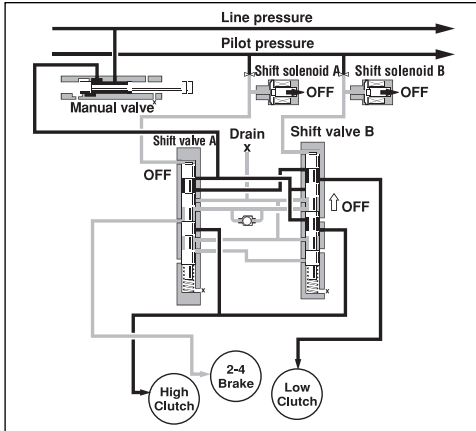

3rd Gear

4th Gear

The TCM turns shift solenoid A ON and B OFF. Pilot pressure is supplied to the top of shift valve A which results in the valve moving downward closing the passage for the Low Clutch and opening the passage for the 2-4 brake. The High Clutch and 2-4 brake are now applied.

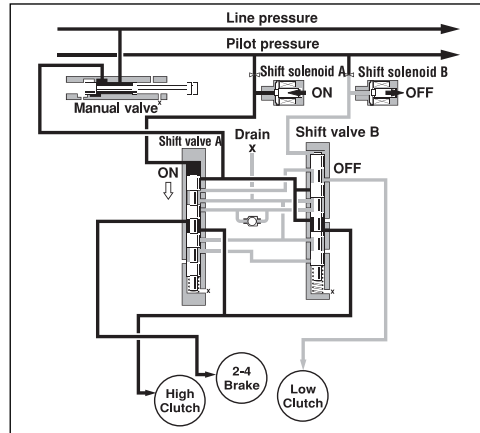

4th Gear

TCM Control

Normal Shifting

The logic for all gear ranges is stored in the TCM memory and is mainly influenced by throttle opening and vehicle speed. Monitoring of these signals enables the TCM to turn the shift solenoids ON or OFF, enabling up and down shifting.

4EAT Phase 2 Overview

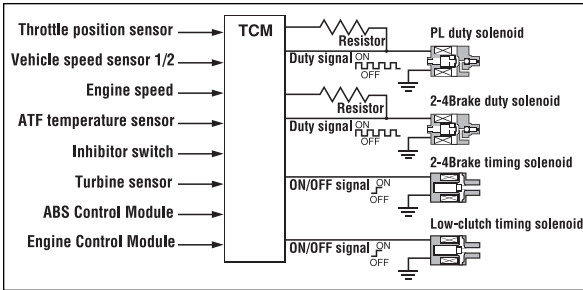

Inputs / Outputs #1

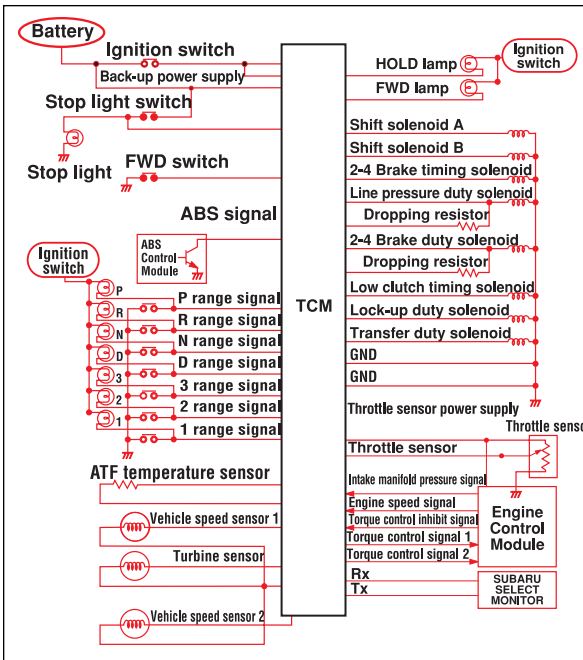

Inputs / Outputs #2

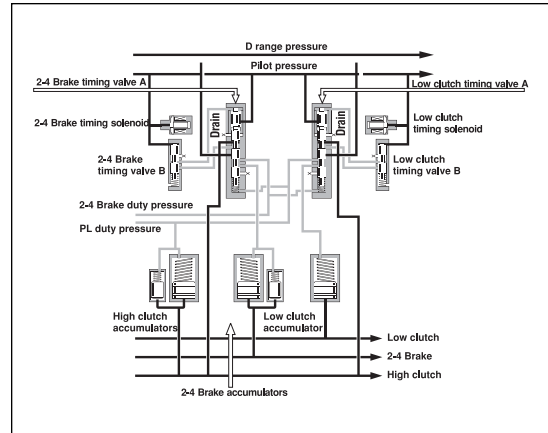

2-4 Brake Timing

Timing Control

Timing control is designed to prevent shift shock and engine racing. Two types of timing control are used with the new EAT: 2-4 brake timing and Low Clutch Timing.

2-4 brake timing is utilized during the upshift from 2nd to 3rd gear. This control temporarily engages both the 2-4 brake and the high clutch, preventing shift shock and engine racing when upshifting from 3rd to 4th gear.

When the TCM turns the 2-4 brake timing solenoid ON, the 2-4 brake-timing valve A is acted upon by the high clutch pressure.

The 2-4-Brake Timing Valve Spool is pushed down as the high clutch pressure overcomes the set pressure.

The movement of the spool valve changes the draining characteristics of the 2-4 brake accumulators. The faster the back pressure of the accumulators drain, the faster the release of the 2-4 Brake Clutch.

Slope Control

This control regulates shifting up from 3rd to 4th gear when traveling uphill and forcefully downshifts from the 4th to 3rd gear when traveling downhill.

The TCM determines the driving force of the traveling vehicle from input of the speed sensor signals, throttle signal, turbine sensor signal, etc., and forcefully maintains 3rd gear.

Control at Low Temperature

To prevent shift shock, shifting up to D range 4th gear is not performed when the ATF temperature is below approximately 12 degrees C.

Control During ABS Operation

During ABS operation the TCM forces the transmission to 3rd gear. This allows the ABS control to exhibit its maximum effect.

Engine Over Speed Prevention Control

Engine over speed is controlled by a fuel cut.

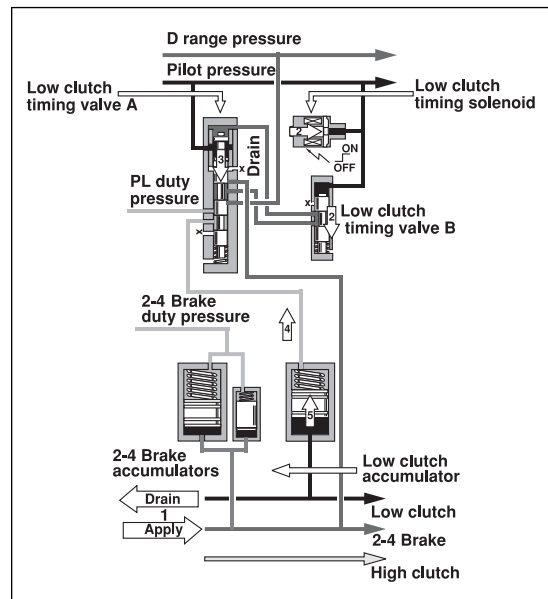

Low Clutch Timing

Low Clutch Timing Control

Low Clutch Timing Control is designed to prevent shift shock and engine racing when the transmission is upshifting from 3rd to 4th gear.

During the upshift to 4th gear, the 2-4 Brake Clutch and the Low Clutch are temporarily engaged together. At the same time the Low Clutch Timing Solenoid is activated, controlling the pilot pressure applied to the top side of the Low Clutch Timing Valve B.

The movement of the Low Clutch Timing Valve B spool regulates the 2-4 brake apply pressure to the top of Low Clutch Timing Valve A. When this pressure overcomes the set pressure the spool valve moves down, changing the draining characteristics of the Low Clutch accumulator back pressure. The faster the back pressure of the accumulator drains, the faster the Low Clutch fully disengages.

Control Performed by the PL Duty Solenoid and the 2-4 Brake Duty Solenoid

The line pressure duty solenoid and the 2-4 brake duty solenoid are adjusted to set values determined from pre-existing conditions of the vehicle just before an up shift or

down shift occurs. This set value is lower than the applied value and is designed to prevent shift shock and improve shifting characteristics.

The drop in both duty pressures cause the accumulator control valve A and B spool valves to move up, and the low clutch and 2-4 brake accumulator back pressures to be reduced.

This allows the accumulators to absorb a larger shock when the clutches are applied.

The turbine sensor detection signal inputted to the TCM influences the rate in which the duty ratios are increased.

Downshifting from 4th to 3rd

The line pressure and 2-4 brake duty solenoid are adjusted to a lower set value just before the actual downshift.

This drops the back pressure in the high and 2-4 brake accumulators. The lowered back pressure allows the applied pressures to be lower, creating a slipping condition of the high and 2-4 brake. Higher engine speeds will then be obtained, generating a higher driving force to the rear internal gear.

The TCM gradually increases the duty ratios eliminating the slip.

4EAT Phase 2 Overview

Engine Torque Control

Engine torque control is performed by the engine control module, which lowers the engine torque by retarding the engine ignition timing and cutting the fuel supply, reducing shift shock.

While shifting is in progress, the TCM detects the brake and clutch engagement and release conditions by comparing the turbine sensor signal and the speed sensor signals. The TCM outputs a signal to the ECM to reduce the torque when set conditions are reached.

Learning Control

Learning control is utilized to prevent shift shock that is created because of clutch and brake wear.

The TCM always detects the turbine sensor signal after starting shift control. It measures the time from when this signal changes until the clutch or brake starts to engage and the time from that point until the clutch or brake fully engages.

The TCM compares these times to their respective target values and determines the clutch or brake status. Based on the results, it decides the operating characteristics of the line pressure control solenoid and the 2-4 brake duty solenoid. By controlling the line pressure control solenoid and the 2-4-Brake solenoid based on these operating characteristics, increased shift shock due to change with passage of time can be prevented.

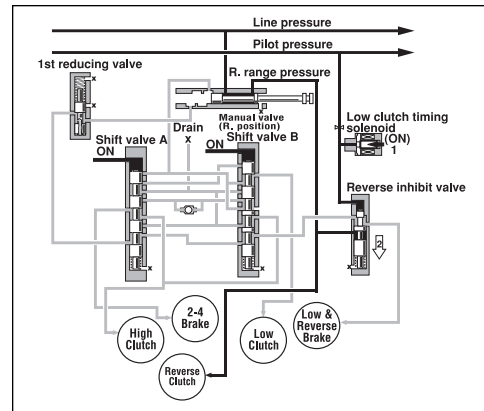

Reverse Inhibit Control

Reverse Inhibit Control

Designed to prevent the accidental shift into reverse gear. This feature is only active above 6 mph. The Low Clutch Timing solenoid is turned on allowing pilot pressure to build up on the top side of the Reverse Inhibit valve. The valve spool is then pushed down blocking the passageway to the low and reverse brake.

Engine Brake Control

Engine brake operation will occur in the 1 range 1st gear. The TCM turns the Low Clutch Timing Solenoid

Self Diagnosis

The TCM detects trouble in the detection signals from the sensors and the signals output to the actuators. This function is referred to as the self diagnosis function. When either signal is faulty, the TCM indicates system trouble by flashing the ATF lamp in the combination meter. By counting the flashes of the lamp a trouble code can be specified.

Code	Item	Diagnosis	Trouble
11	Line pressure duty solenoid	Short or Disconnection in solenoid driving circuit	More severe shifting shock and faulty shifting
12	Lockup duty solenoid	Short or disconnection in solenoid driving circuit	Fails to lock up (after warm-up)
13	2-4 brake timing solenoid	Short or disconnection in solenoid driving circuit	Faulty shifting
14	Shift solenoid B	Short or disconnection in solenoid driving circuit	Fails to shift
15	Shift solenoid A	Short or disconnection in solenoid driving circuit	Fails to shift
16	2-4 brake duty solenoid	Short or disconnection in solenoid driving circuit	Faulty shifting
21	ATF temperature sensor	Short or disconnection in input circuit	Faulty shifting when cold
22	Pressure sensor	Short or disconnection in input circuit	More severe shifting shock
23	Engine speed signal	No signal input above 10km/h	Fails to lock up (after warm-up)
24	Transfer duty solenoid	Short or disconnection in solenoid driving circuit	Excessive tight corner braking phenomena
25	Engine torque control signal	Short or disconnection in engine torque control signal circuit	More severe shifting shock
31	Throttle sensor	Short or disconnection in input circuit	Faulty shifting and excessive shifting shock
32	Vehicle speed sensor 1	No signal input to speed sensor 1 above 20km/h	Speed sensor 1 malfunctions: more severe shifting shock
33	Vehicle speed sensor 2	No signal input to speed Sensor 2 above 20km/h	One or the other malfunctions: excessive tight corner braking phenomena Both malfunction: fails to shift
34	Turbine sensor	No signal input in ranges other than N range (vehicle speed sensors 1 and 2 are operating normally while vehicle is traveling)	More severe shifting shock
36	Low clutch timing solenoid	Short or disconnection in solenoid driving circuit	Faulty shifting

ON and supplies pilot pressure to the reverse inhibit valve. The pilot pressure causes the reverse inhibit valve spool to move downward, opening the port to the low and reverse brake. Pressure from the 1st reducing valve engages the low and reverse brake. The Low Clutch Drum is then fixed to the transmission case and the rotation of the wheels is transmitted to the engine side, operating the engine brake effect. ■

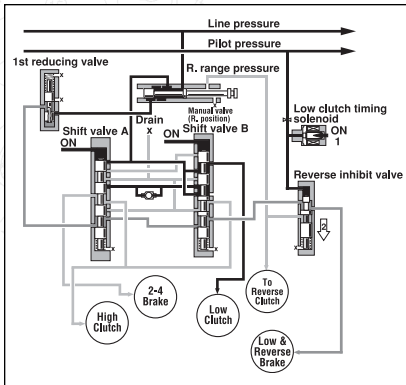

Reverse Inhibit Control

Failsafe Function

Failsafe function is a TCM controlled function that enables the vehicle to be driven in the event of malfunction of the vehicle speed sensors, throttle sensor, inhibitor switch or various solenoids. In the event of trouble the TCM executes the following control.

Item	Failsafe Function
Line pressure duty solenoid	TCM turns the solenoid off and sets the transmission so only 1st and 3rd are available. The line pressure is also set to maximum.
Lockup duty solenoid	TCM turns the solenoid off and torque converter lock up does not occur.
2-4 brake timing solenoid	TCM turns the solenoid off and sets the transmission so only 1st and 3rd are available.
Shift solenoid B	When either solenoid malfunctions the TCM turns both solenoids off and sets the transmission to 3rd gear.
Shift solenoid A	When either solenoid malfunctions the TCM turns both solenoids off and sets the transmission to 3rd gear.
2-4 brake duty solenoid	TCM turns the solenoid off and sets the transmission so only 1st and 3rd are available
Transfer (AWD) duty solenoid	TCM turns the solenoid off and adjusts the transfer clutch pressure to maximum.
Throttle sensor	TCM assumes the throttle opening of 3/8 open and continues at that level.
Vehicle speed sensor 1	Vehicle speed sensor 2
Vehicle speed sensor 2	Vehicle speed sensor 1 (If both sensors malfunction, the TCM sets the transmission to 3rd gear.)
Low Clutch Timing Solenoid	TCM turns the solenoid off and sets the transmission so only 1st and 3rd are available.